



# Air Treatment Products

L20381 Rev 7/07



## Air Treatment : Clean Air for Long Life

DRYest<sup>®</sup>

PURest<sup>®</sup>

Consep<sup>™</sup>

Automatic Drain Valve

ModulAir<sup>™</sup>



## A Combination of Products Results in Superior Air Treatment

Applying “Innovative Vehicle Technology” to every aspect of the braking system



### Air Treatment Products

While every Haldex air treatment product can be used individually, using a combination of products results in superior air treatment for maximum efficiency. Using the Consep™ before either the PURest® or DRYest® air dryers significantly increases the desiccant cartridge life for reduced maintenance and downtime costs. By aggressively removing contaminants from the air system, premature wear, corrosion and freeze-up is minimized. The end result is enhanced efficiency and longer service of the entire air system for cost efficient operation over the life of the vehicle. The slide-on-off Multi-Treatment Cartridge of the PURest® and DRYest® simplifies maintenance. The Consep™ uses a simple, filterless design to separate and remove contaminants efficiently with minimal maintenance. The Automatic Drain Valve (ADV) automatically releases moisture from the tanks each time the brakes are applied.

### Clean Air Ensures System Efficiency And Reliability – And Reduces Overall Costs

Haldex air treatment products work individually or in combination to minimize the build-up of water, oil, and other contaminants while simultaneously minimizing maintenance. Contaminants in the system clog valves, deteriorate rubber parts, and wash away necessary system lubricants. This leads to corrosion, premature wear and freeze-up, which compromises system efficiency and can cause costly system failure and unnecessary downtime.

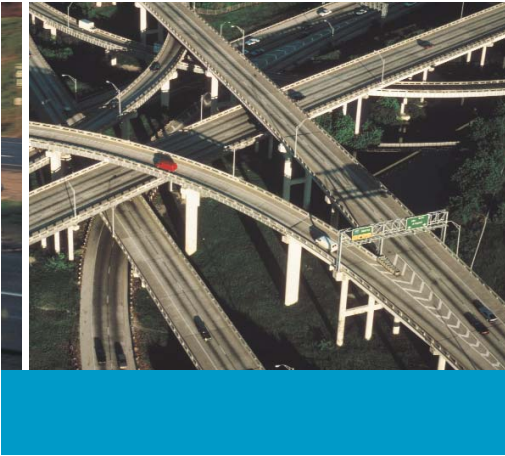

## Four Reliable Products

The Haldex air treatment family consists of four reliable products – the PURest® and DRYest® air dryers with Multi-Treatment Cartridge (MTC), the Consep™ Condenser/Separator, and the Automatic Drain Valve (ADV). Each Haldex air treatment product is designed for easy installation, reliability, and long service life. They are perfect examples of how Haldex is applying “innovative vehicle technology” to every aspect of the braking system.



The Consep™ (Condenser/Separator) uses a simple, filterless design to separate and remove contaminants efficiently with minimal maintenance. The Automatic Drain Valve (ADV) automatically releases moisture from the tanks each time the brakes are applied as a first line of defense. The large volume desiccant cartridges of the DRYest™ and PURest™ simplify maintenance.



## Multi-Treatment Cartridge: For Clean Dry Air

Representing the new generation of desiccant cartridge air treatment systems, the patented technology of the Haldex **MTC** is an extremely efficient drying system, removing up to 99% of contaminants in the compressed air system while treating up to 30 CFM. That performance makes it ideal for systems with high air consumption.

The **MTC** provides exceptional airflow while minimizing the risk of getting water or contaminants into the brake system. This in turn reduces opportunities for corrosion and freezing problems, as well as protecting the rubber and plastic components from aggressive, destructive hydrocarbons in the air brake system.

The efficiency, reliability and ease of installation are unmatched by any competitor. The heart of the unique functionality of Haldex air dryers is our new interchangeable, high performance **MTC**, which is now utilized on all Haldex Cartridge Type Air Dryers.

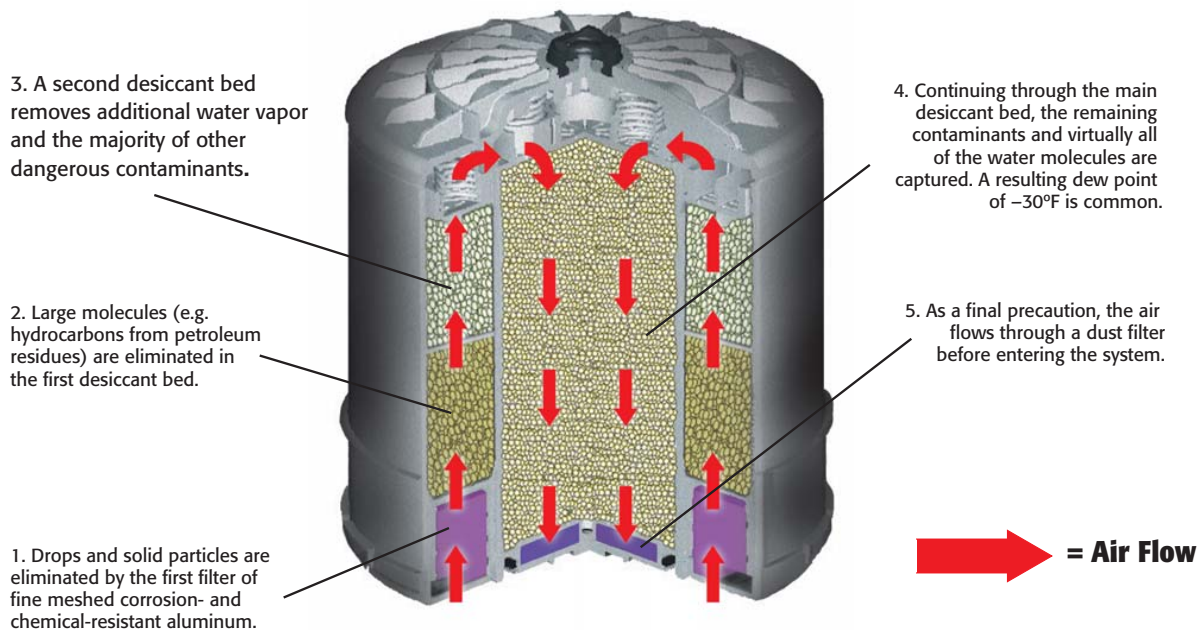

**Quick Change:** The cartridge can be removed by lifting it a mere 10mm off of the base plate. This slide-in-out design allows for quick installation and quick replacement—while saving space.

**Regeneration:** With every compressor cycle, the dryer back flushes a volume of air through the MTC for cleaning of the filters.

**Safety:** Because you don't have to replace the entire unit—just the cartridge—the canister can be built to last, and with great safety. The one supplied by Haldex is designed to last the lifetime of the dryer due to low mechanical stresses and great heat and chemical resistance.





## For Your SYSTEM PURGE Applications...

The Haldex DRYest® is designed to provide clean system air with the lowest initial system and lifetime costs.

This is accomplished by being the most integrated Air Dryer available. DRYest® comes with integrated: turbo protection valve, governor, regeneration valve, muffler, and heater. DRYest® adapts to fit YOUR application.

Typically this dryer is used in a system where the secondary tank works in conjunction with the regeneration valve to purge the dryer. However DRYest® can be used with auxiliary purge tanks or even be used with European unloader systems where the compressor unloads through the dryer.

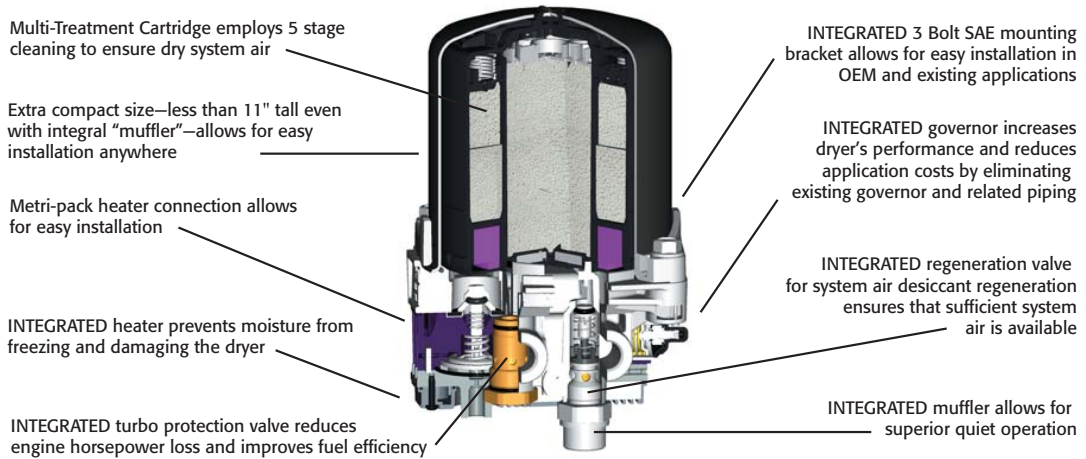

For Severe Applications, use Consep™ as a pre-treatment device to ensure the highest quality air possible and to extend desiccant life.



## For Your INTEGRATED PURGE Applications...

The Haldex PURest® is designed to provide clean system air with minimal initial and lifetime cost. The key is the successful combination of the highly efficient Multi-Treatment Cartridge and a large purge volume.

The large integrated purge volume eliminates the need for a separate purge tank. The PURest® also features a unique mounting bracket that eases retro-fit installation regardless of what air dryer is currently used in the system.

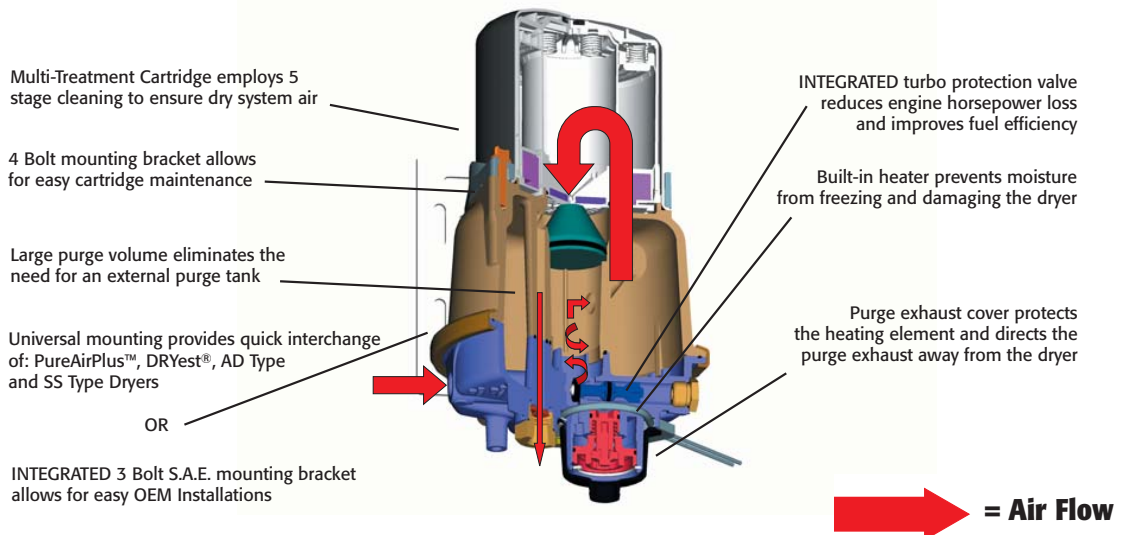

For Severe Applications, use Consep™ as a pre-treatment device to ensure the highest quality air possible and to extend desiccant life.

# Solutions to Ensure Air System Performance and Longevity

## Consep™: Low-Maintenance Condenser/Separator

The Haldex Consep™ efficiently accomplishes three critical functions for air system performance: condensing, separating, and expelling 90% of contaminants. It is ideal for less demanding systems or for high air use vehicles as a pre-treatment before the air dryer where it typically doubles the life of the dryer's desiccant cartridge. The Consep™ requires very minimal maintenance over its long service life. It employs a circular air path where the air is cooled, causing the contaminants to fall out. The condensate then runs down to the bottom of the unit where liquids are expelled through the integrated drain valve at the next brake application. Easy installation and reliable operation make the Consep™ an ideal solution to ensure air system performance and longevity with minimal costs.



### Consep™ Operation

The circular air path of the Consep™ and external cooling fins cause liquid and oils to condense and separate from the air before continuing on through the system.

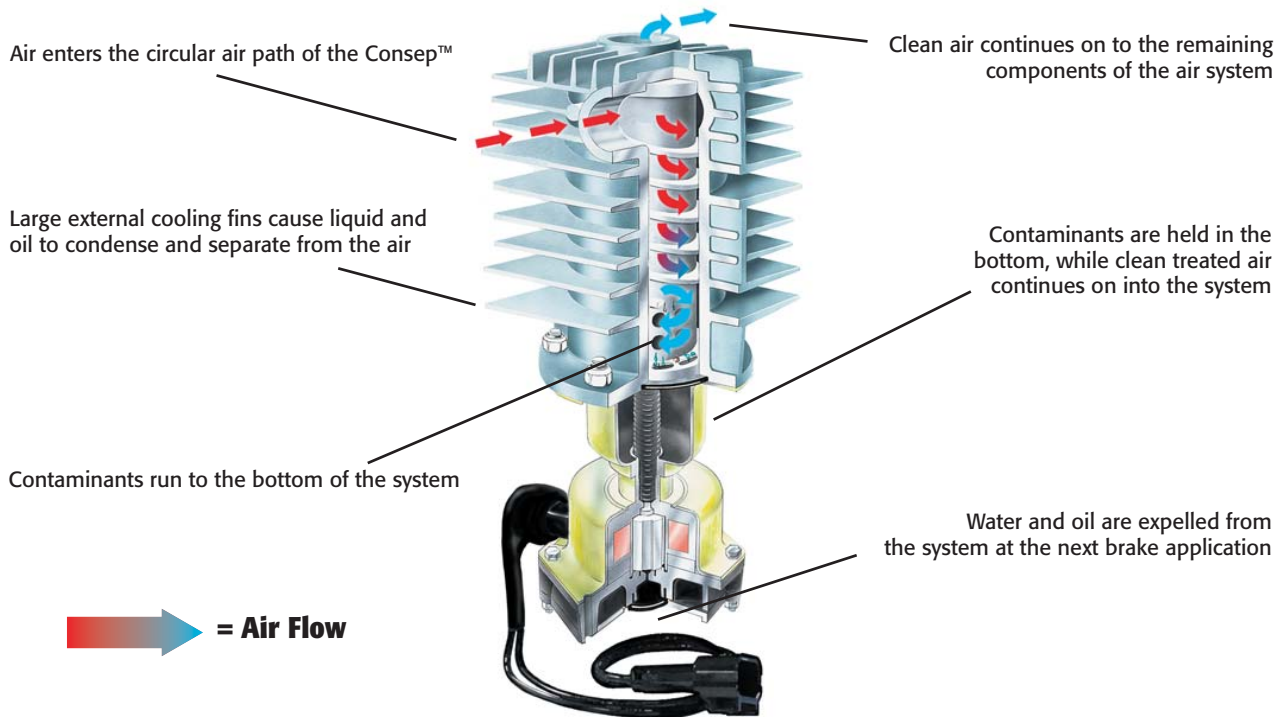

## Automatic Drain Valve: Trouble-free Liquid Removal

The Haldex Automatic Drain Valve (ADV) uses a unique design to remove liquids from the compressed air tank. Each time the brake is applied, any accumulated moisture is expelled. Eliminating manual drain valves saves operators time while ensuring that the liquid is removed regularly for optimum system performance. And like all Haldex air treatment products, the ADV is simple to install or retrofit to existing air reservoirs.

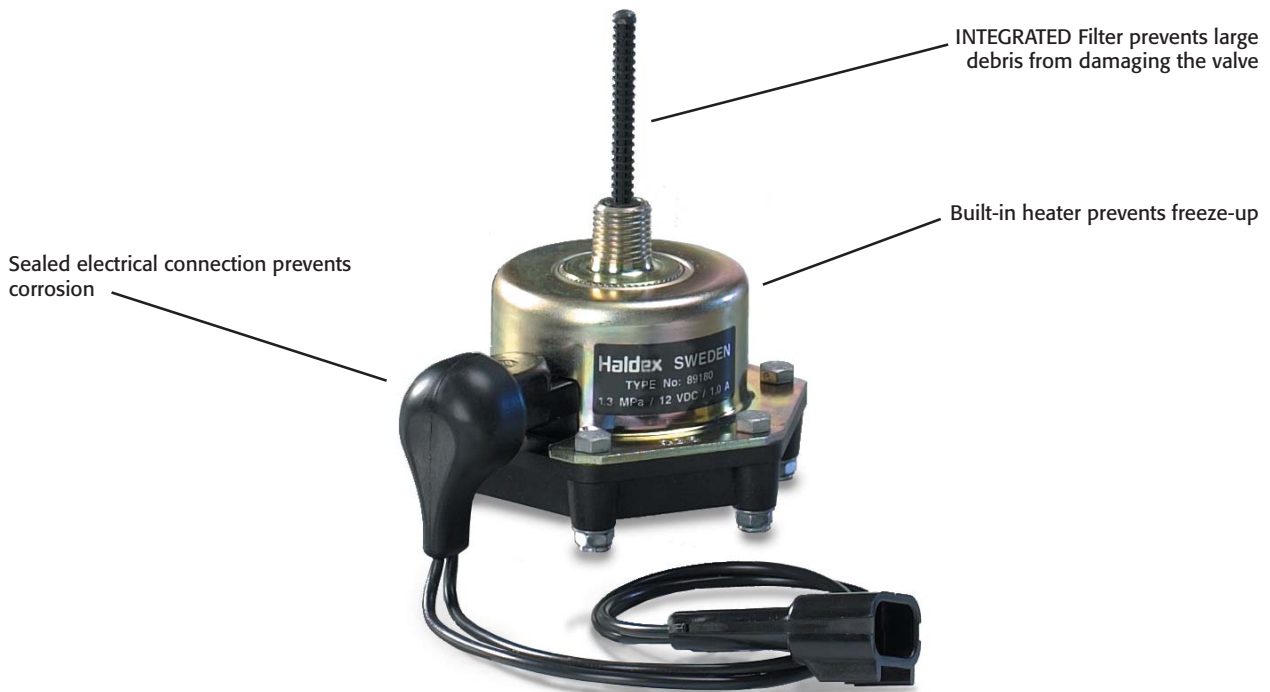

## ModulAir™: The Future Of Air Treatment

The future of air treatment, a Modular Air Treatment Unit (ModulAir™), combines the functions of the air dryer, governor, and pneumatic valves into one unit, which is capable of interaction with the engine management system and other vehicle systems. The ModulAir™ system eliminates the need for multiple valves and provides a dramatic improvement in air system performance.



*The ModulAir™ will minimize air components  
on heavy vehicles of the future.*

**Haldex is a world leader in air treatment technology and braking technology in general. One of the reasons for our success is a willingness to work with customers to design an air treatment system specifically for their vehicles. Our customers will play a critical role as we develop and refine advanced electronic air treatment technology.**

Haldex offers proprietary vehicle technology solutions to the global vehicle industry within specific niches. We focus on products to improve safety, the environment and vehicle dynamics.

We are enhancing our competitive capabilities and building long-term customer relationships through high performance, low total costs to the customer through the product's service life, ethical business practices and commitment to long-term partnerships. Haldex operations are divided into four business areas: Commercial Vehicle Systems, Hydraulic Systems, Garphyttan Wire and Traction Systems.

### **Austria**

Haldex Wien Ges.m.b.H.  
Vienna  
Tel.: +43 1 8 65 16 40  
Fax: +43 1 8 65 16 40 27  
E-Mail: info.AT@Haldex.com

### **Belgium**

Haldex N.V./S.A.  
Balegem (Ghent)  
Tel.: +32 9 363 90 00  
Fax: +32 9 363 90 09  
E-Mail: info.BE@Haldex.com

### **Brazil**

Haldex do Brasil Ind. e Com, Ltda.  
São Paulo  
Tel.: +55 11 213 55 000  
Fax: +55 11 503 49 515  
E-Mail: info.BR@Haldex.com

### **Canada**

Haldex Ltd  
Guelph, Ontario  
Tel.: +1 519 826 7723  
Fax: +1 519 826 9497  
E-Mail: info.CA@Haldex.com

### **China**

Haldex International Trading Co. Ltd.  
Shanghai  
Tel.: +86 21 5240 0338  
Fax: +86 21 5240 0177  
E-Mail: info.CN@Haldex.com

### **France**

Haldex Europe SAS  
Weyersheim (Strasbourg)  
Tel.: +33 3 88 68 22 00  
Fax: +33 3 88 68 22 09  
E-Mail: info.EUR@Haldex.com

### **Germany**

Haldex Brake Products GmbH  
Heidelberg  
Tel.: +49 6221 7030  
Fax: +49 6221 703400  
E-Mail: info.DE@Haldex.com

### **Hungary**

Haldex Hungary Kft.  
Szentlőrincváta  
Tel.: +36 29 631 300  
Fax: +36 29 631 301  
E-Mail: info.HU@Haldex.com

### **India**

Haldex India Limited  
Nasik  
Tel.: +91 253 2380094  
Fax: +91 253 2380729  
E-Mail: info.IN@Haldex.com

### **Italy**

Haldex Italia Srl.  
Muggio (Milano)  
Tel.: +39 039 278 23 50  
Fax: +39 039 796 525  
E-Mail: info.IT@Haldex.com

### **Poland**

Haldex Sp. z.o.o.  
Praszka  
Tel.: +48 34 350 11 00  
Fax: +48 34 350 11 11  
E-Mail: info.PL@Haldex.com

### **Russia**

OOO Haldex RUS  
Moscow  
Tel.: +7 495 747 59 56  
Fax: +7 495 786 39 70  
E-Mail: info.RU@Haldex.com

### **South Korea**

Haldex Korea Ltd.  
Seoul  
Tel.: +82 2 2636 7545  
Fax: +82 2 2636 7548  
E-Mail: info.KR@Haldex.com

### **Spain**

Haldex España S.A.  
Parets del Valles (Barcelona)  
Tel.: +34 93 573 10 30  
Fax: +34 93 573 07 28  
E-Mail: info.ES@Haldex.com

### **Sweden**

Haldex Brake Products AB  
Landskrona  
Tel.: +46 418 47 60 00  
Fax: +46 418 47 60 01  
E-Mail: info.SE@Haldex.com

### **United Kingdom**

Haldex Ltd.  
Newton Aycliffe  
Tel.: +44 1325 310 110  
Fax: +44 1325 311 834  
E-Mail: info.GBAy@Haldex.com

Haldex Brake Products Ltd.

Redditch  
Tel.: +44 1527 499 499  
Fax: +44 1527 499 500  
E-Mail: info.GBRE@Haldex.com

### **USA**

Haldex Brake Products Corp.  
Kansas City, MO  
Tel.: +1 816 891 2470  
Fax: +1 816 891 9447  
E-Mail: info.US@Haldex.com

©2007, Haldex AB - This material may contain Haldex trademarks and third party trademarks, trade names, corporate logos, graphics and emblems which are the property of their respective companies. The contents of this document may not be copied, distributed, adapted or displayed for commercial purposes or otherwise without prior written consent from Haldex.

Commercial Vehicle Systems

L20381 US Rev. 7/07 10M CUT



[www.haldex.com](http://www.haldex.com)

[www.hbsna.com](http://www.hbsna.com)